



8012 2636  
3834 1299

6983 0912  
7846 2189

6733 6032  
1464 0085

6983 0912  
7846 3525

8012 2636  
3834 1299

6983 0912  
7846 2189

6733 6032  
1464 0085

6983 0912  
7846 3525

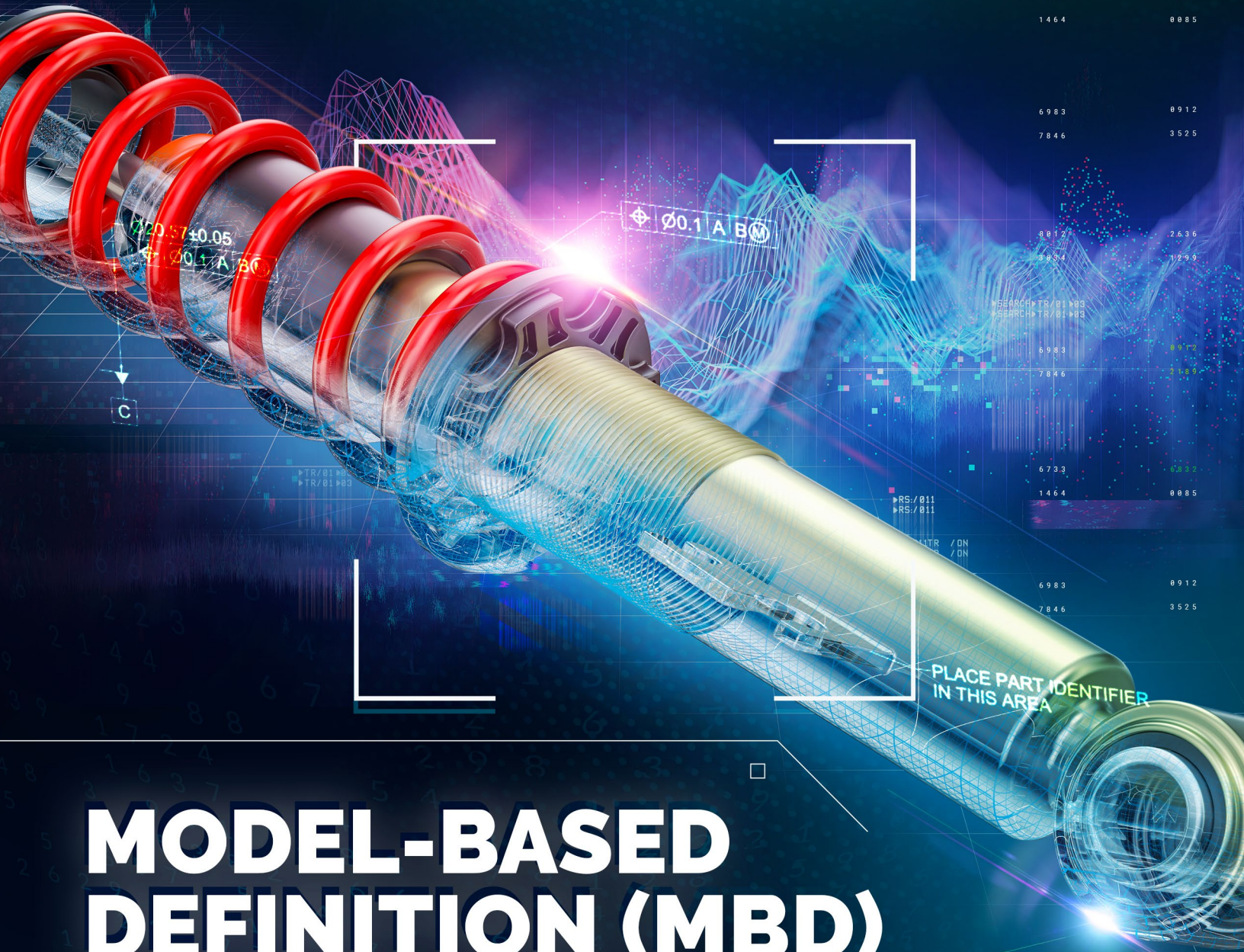

# MODEL-BASED DEFINITION (MBD) CAPABILITIES IN CREO

With Creo's capabilities, everyone in the enterprise can have what they need: a 3D annotated model with fully semantic, correctly applied Product Manufacturing Information (PMI).



# MODEL-BASED DEFINITION (MBD) CAPABILITIES IN CREO

Model-based definition (MBD) provides clarity in a complex world. An approach to product engineering, MBD is about creating, organizing, and managing a 3D Model and the attendant semantic (machine readable) Product Manufacturing Information (PMI). This fully defined model captures design intent and geometric form control, serving as the single source of truth for the entire enterprise. Everyone from the executive offices to the shop floor can interrogate the model using either the model itself or a plug-and-play viewer.

Whether you're a long way in your MBD journey or starting to take a first look, you'll find capabilities in Creo to help you.

## CAPABILITIES IN EVERY SEAT

From the first moment you open Creo, you can define and manage semantic PMI notations.

## FEATURES AND BENEFITS

- Quick and easy creation, placement and editing of: semantic dimensions, geometrical tolerances, datum feature symbols, datum targets, notes, tables, symbols and surface finish
- Rich contextual properties ribbon and dynamic preview of the selected changes
- Syntax checking for GD&T annotations according to industry standards (ASME Y14.5-2009/2018; ISO 1101:2012/2017)
- Support for the common industry MBD standards: ASME Y14.41; ISO 16792
- ISO/ASME standard-compliant text symbols
- Easy reference management of annotations to geometry using individual & rule-based collection methods
- Reporting of semantic reference failures of annotations
- Reporting of failures of semantic references
- Designation of annotations to Windchill MPMLink for manufacturing process planning
- Visibility Management and organization of PMI annotation and supplemental geometry in combination states (3D). Further control over visibility of section views, appearance states, orientation states, simplified representations, visibility styles and explode states to easily convey design intent
  - o Control over combination state publishing to Creo View
- Export of semantic PMI to STEP AP242 neutral file
- MBD related queries using Creo ModelCHECK for quick validation of design

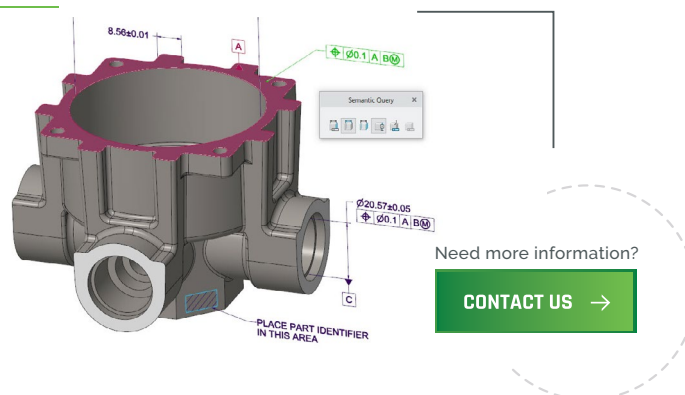

# CREO GEOMETRIC DIMENSIONING & TOLERANCING\* ADVISOR ADVANCED (GD&T ADVISOR ADVANCED)

GD&T is the process of annotating designs and drawings for downstream processes using a symbolic language to define the allowable deviation of feature geometry. It is painstaking manual work, as anyone knows who has spent more time detailing a model than designing it. Worse, the very nature of this complex process means it is prone to error.

GD&T Advisor Advanced provides expert guidance on the application and validation of geometric dimensioning and tolerancing based on the latest standards and helps you avoid mistakes leading to scrap, rework, changes, confusion, and downtime. When your model is complete, you can be confident that it complies with the relevant standard and is fully constrained. The software gives you up-to-date readily available guidance during every step of the application process.

## FEATURES

- Efficient and intelligent application of functionally and syntactically correct GD&T annotations for 3D part & assembly models
- Visual indications of syntactic errors and under-constrained geometry.
- Detailed report about mismatched & unvalidated annotations and user control over required updates
- Extensive help content, informative tool tips, and advisor messages aid in understanding of GD&T concepts
- Ability to leverage existing Creo annotations, evaluate them and fix any found issues (instead of recreating them from scratch)
- Standards Rulesets; ASME Y14.5-2009, 2018 and associated standards; ISO 1101: 2012, 2017 and associated standards

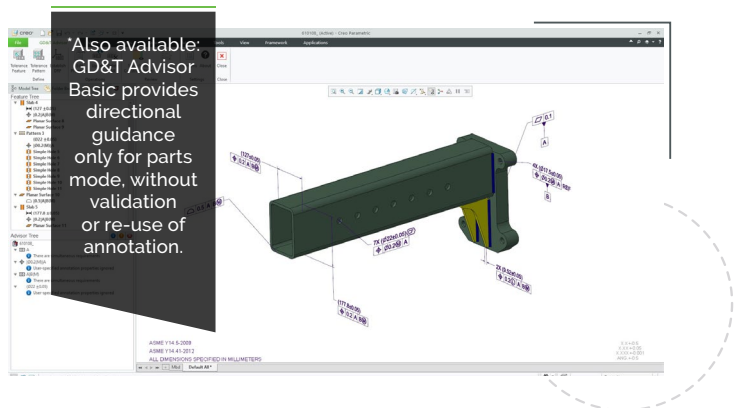

## CREO EZ TOLERANCE ANALYSIS

This powerful tolerance stack-up and gap analysis solution allows you easily to analyze, visualize, and understand the geometric tolerance stack-up and dimensional variation that have an impact on your design. The tool uses statistical tolerance analysis to help you improve the quality and manufacturability of your products.

### FEATURES

- Evaluate the impact of tolerances on the assembly of part designs, highlighting areas of concern.
- Define multiple 1D tolerance stack-up analyses on the same model, using surfaces and features.
- Modify a stored part or its tolerance and immediately update stack-up results.
- Visualize the interactive tolerance loop.
- Evaluate profile, position, concentricity, symmetry, and run-out geometric tolerance.

### CAPABILITIES

- Dashboard tables show the objectives and results of each stack-up analysis, along with a visual indication of whether the requirement has been met
- Auto-generated output plots of contribution and sensitivity, with worst-case, RSS, and statistical results
- Quality metrics for statistical analysis includes Cpk, Sigma, DPMO, and % Yield
- Detailed report with graphical view of the dimension loop and contributors, sorted from largest to smallest
- HTML reports for easy sharing

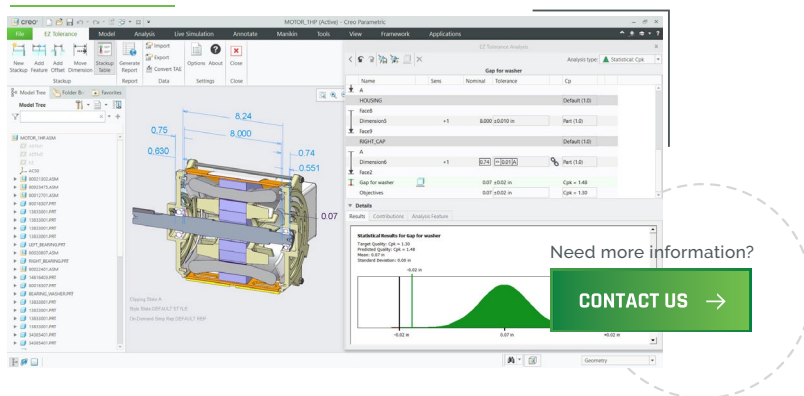

## CREO VIEW SUITE OF VIEWERS

An essential part of the MBD approach to engineering is that everyone – including those who have never opened a CAD tool – should be able to see the 3D CAD model. The Creo View suite of viewers provides this. These visualization tools give marketing, manufacturing, quality, service, and all other non-engineering users single-click access to 3D models, drawings, images and documents. A no-cost option, Creo View Express, provides basic functionality.

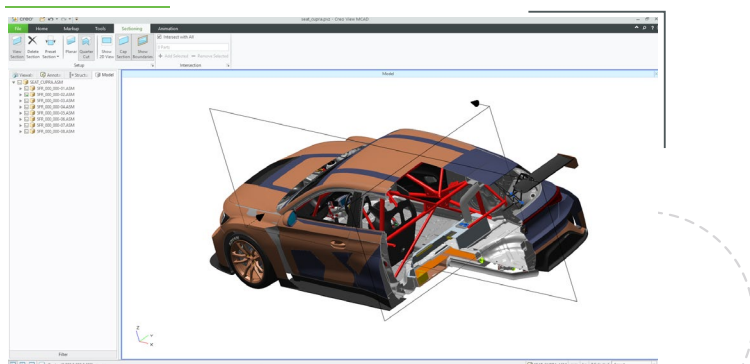

CREO VIEW VISUALIZATION SOFTWARE →

## THE CREO ADVANTAGE

Creo is the 3D CAD solution that helps you accelerate product innovation to build better products faster. Easy-to-learn Creo uses a model-based approach to seamlessly take you from the earliest phases of product design to manufacturing and beyond. Combining powerful, proven functionality with new technologies including generative design, real-time simulation, advanced manufacturing, IIoT and augmented reality, Creo helps you iterate faster, reduce costs and improve product quality. Creo is also available as a SaaS product, providing innovative cloud-based tools for real-time collaboration and streamlined license management and deployment. The world of product development moves quickly, and only Creo delivers the transformative tools you need to build competitive advantage and gain market share.

© 2024, PTC, Inc. All rights reserved. Information described herein is furnished for informational use only, is subject to change without notice, and should not be taken as a guarantee, commitment, condition or offer by PTC. PTC, the PTC logo, and all other PTC product names and logos are trademarks or registered trademarks of PTC and/or its subsidiaries in the United States and other countries. All other product or company names are property of their respective owners [402963\\_Creo\\_11\\_MBD\\_Brochure](#)